

Vortex86SX-NOSKT U1D

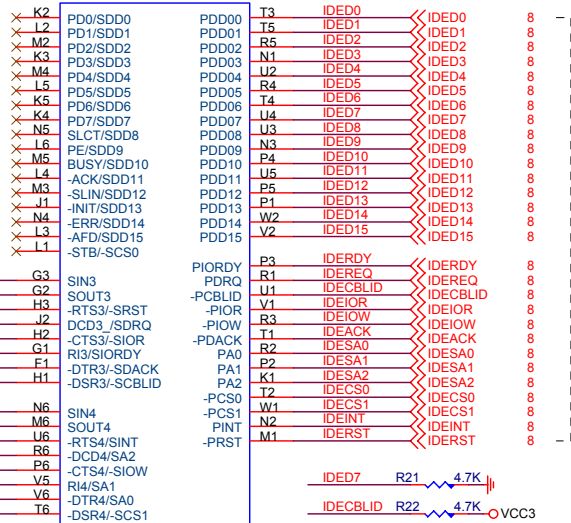

IDE

COM3

COM4

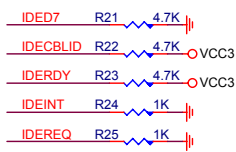

DMP ELECTRONICS INC.

Title: Vortex86SX IDE

Size: Document Number DM90A Rev: 1.2

Date: Monday, February 25, 2008 Sheet 2 of 8

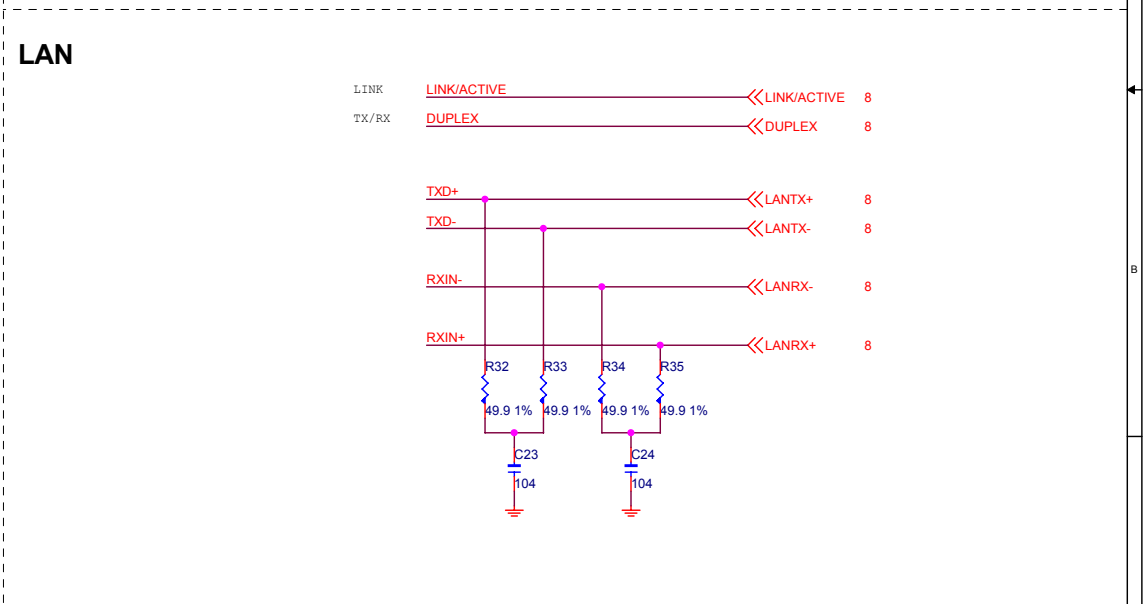
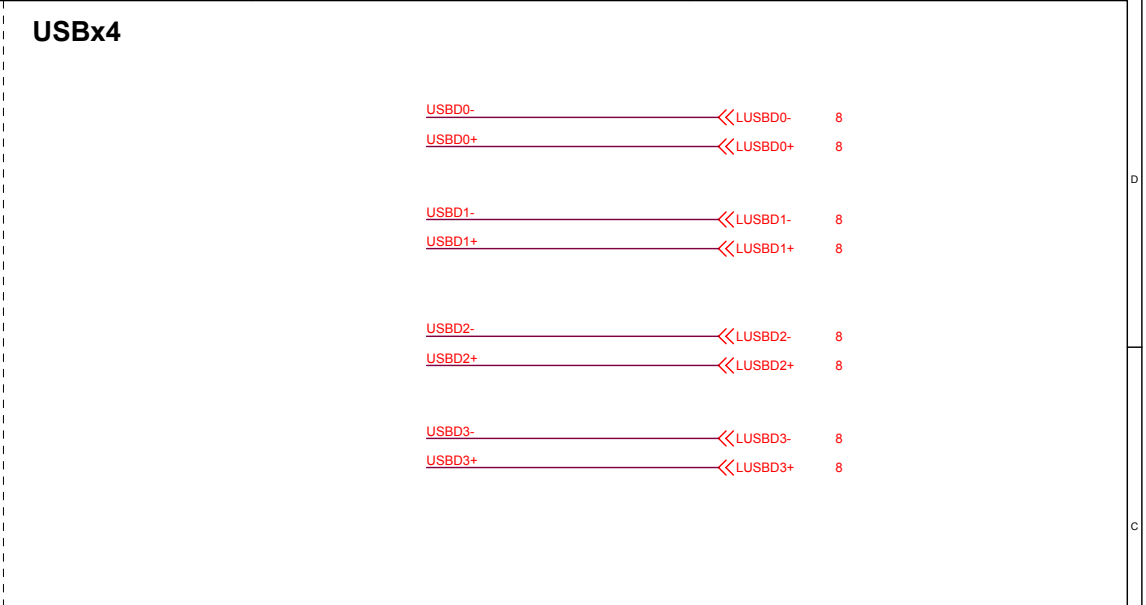
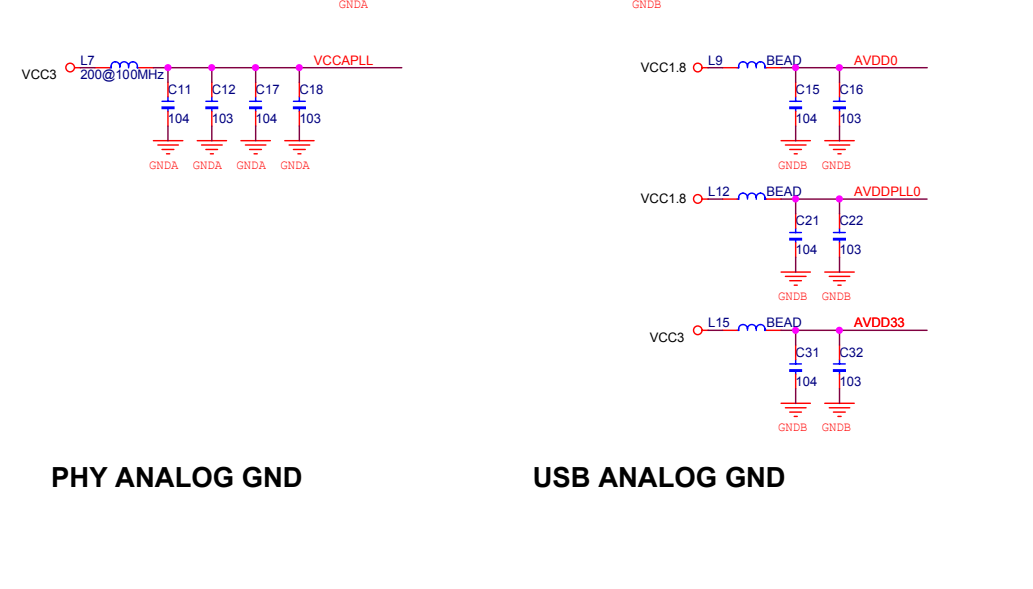
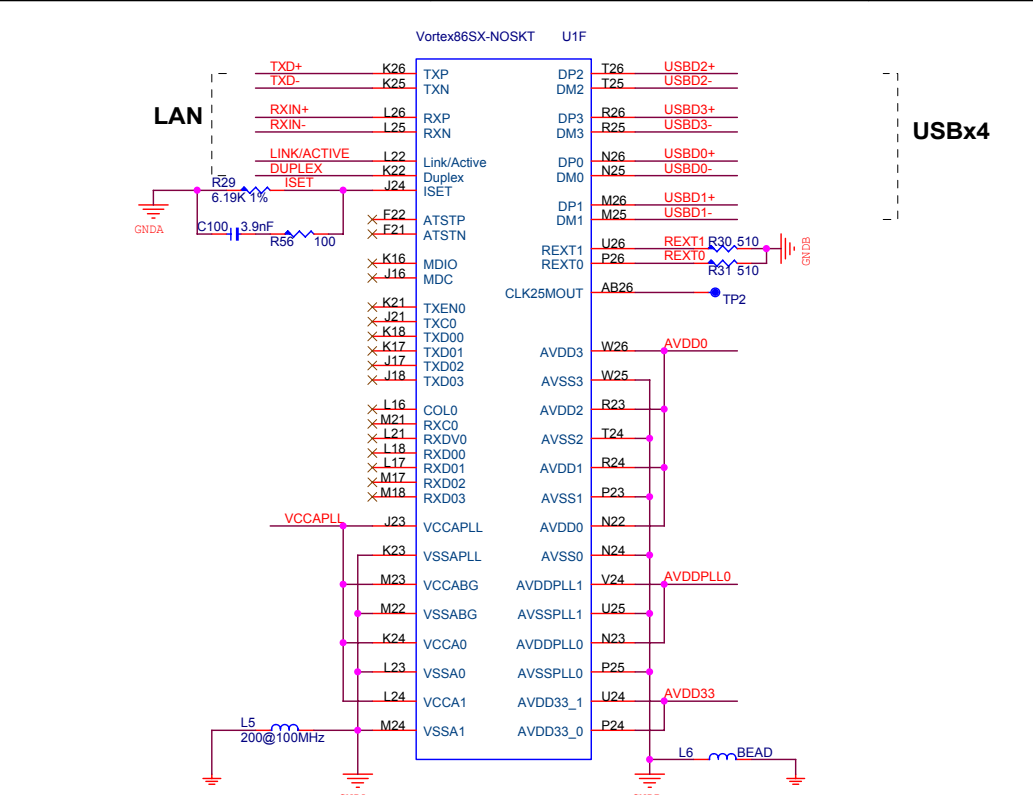

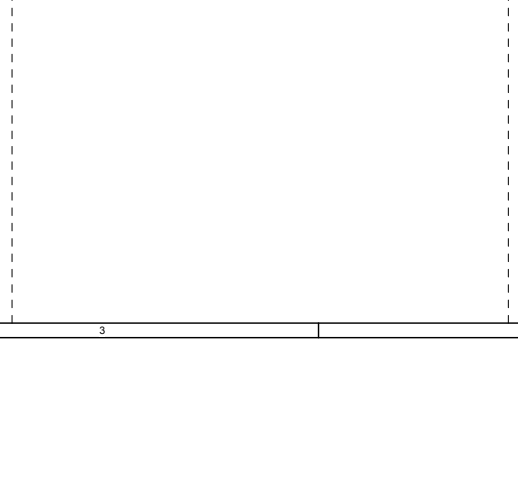
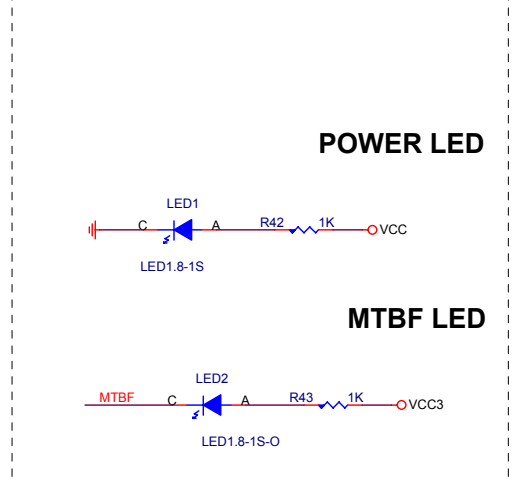
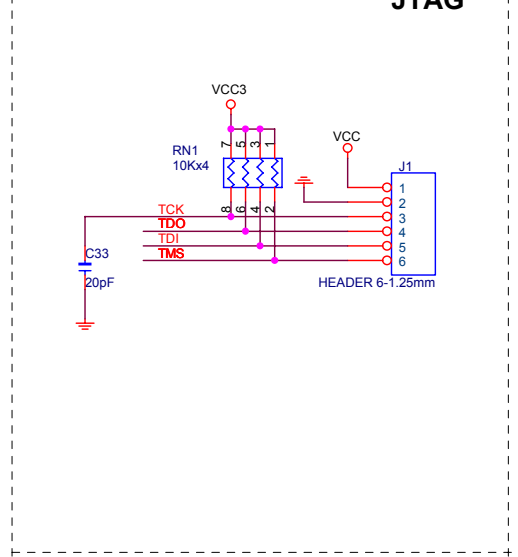
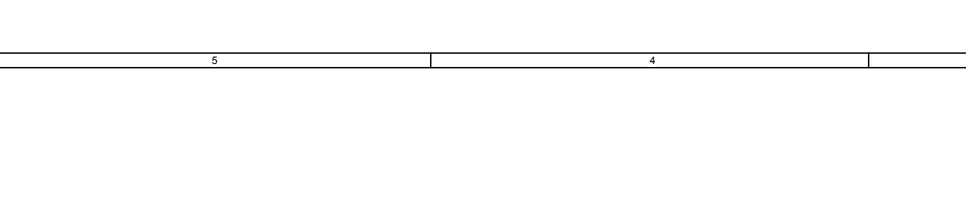
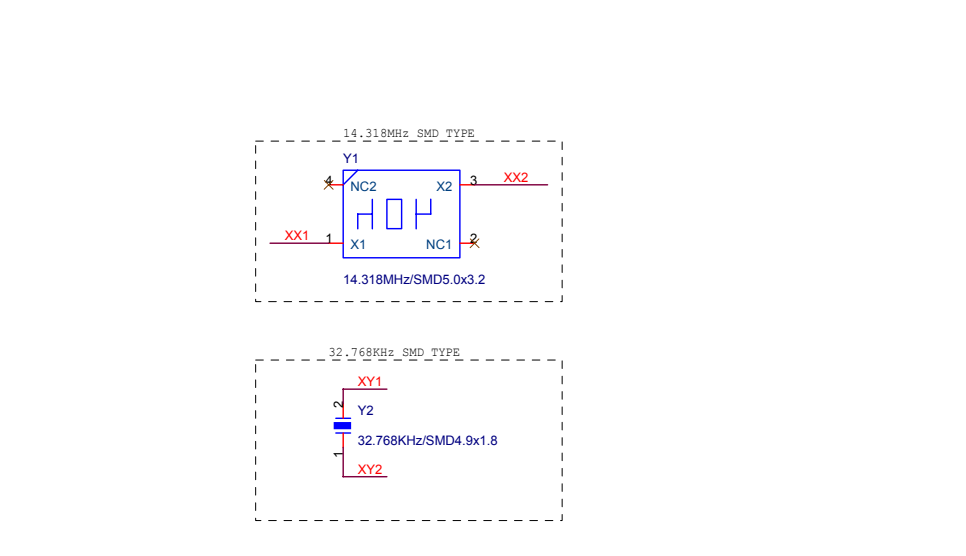
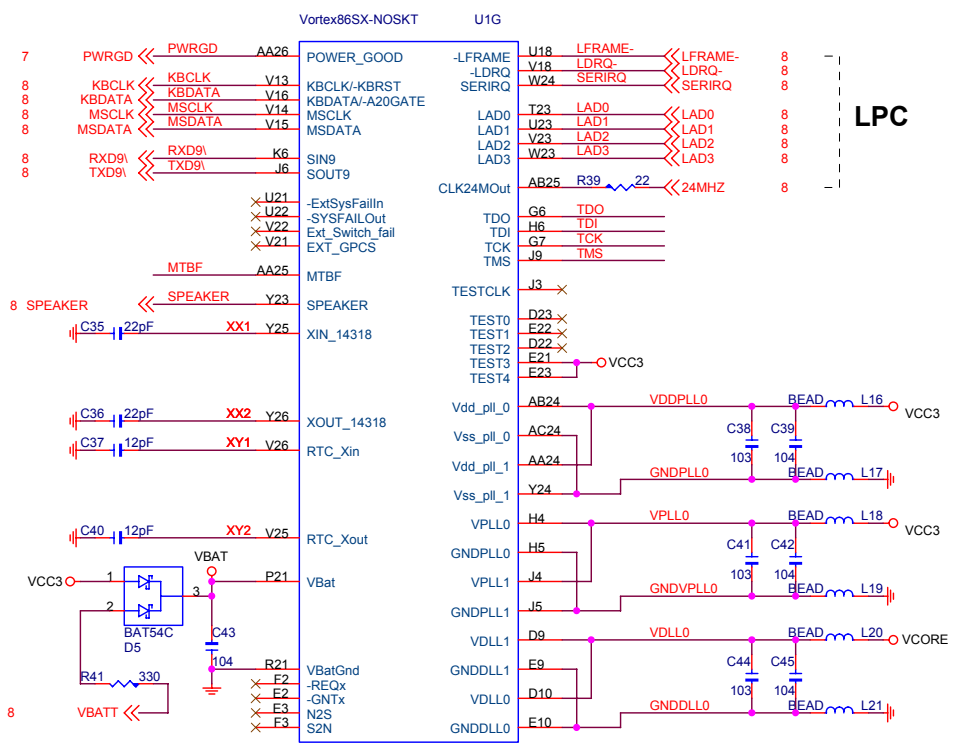

DMP ELECTRONICS INC.

Title: Vortex86SXKBD/MS/LPC/JTAG

Size	Document Number	Rev
	DM90A	1.2

Date: Monday, February 25, 2008 Sheet 5 of 8

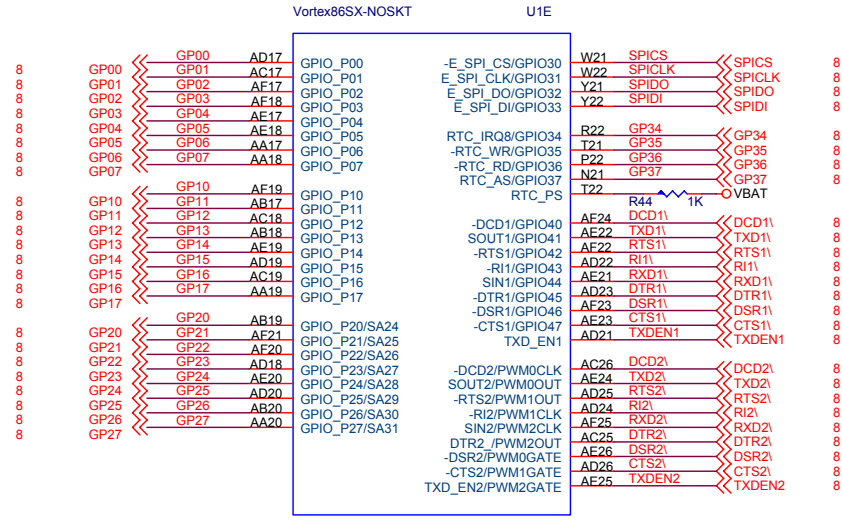

External SPI FLASH 2MB

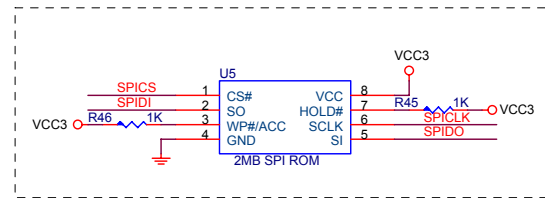

DMP ELECTRONICS INC.



Title		
Vortex86SX GPIO/COM/PWM		
Size	Document Number	Rev
	DM90A	1.2
Date:	Monday, February 25, 2008	Sheet 6 of 8

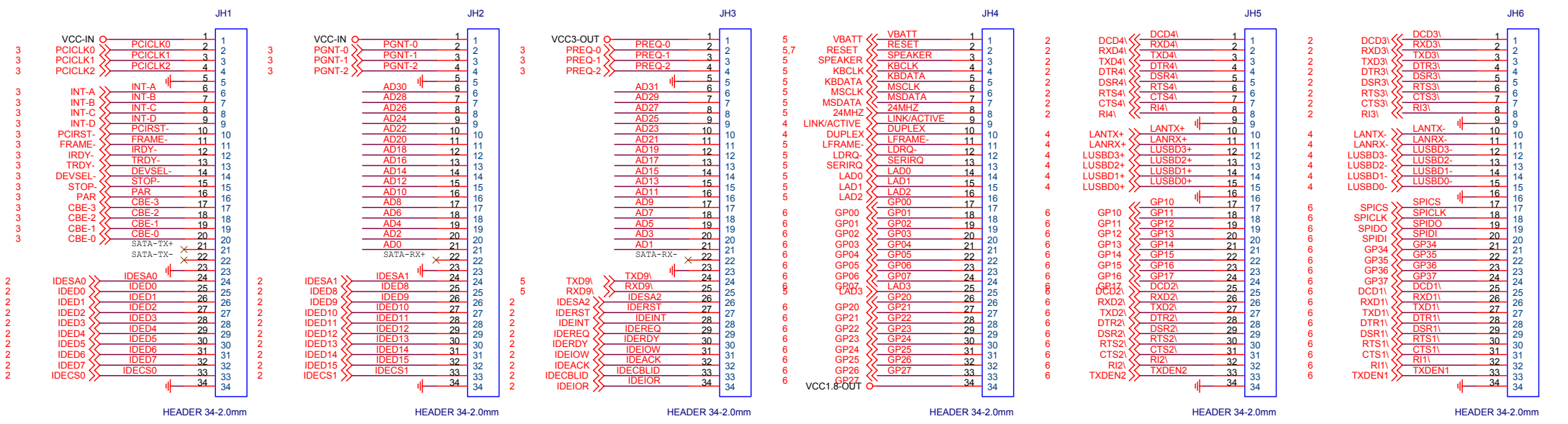

3 AD[0..31] >> AD[0..31]

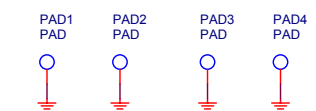
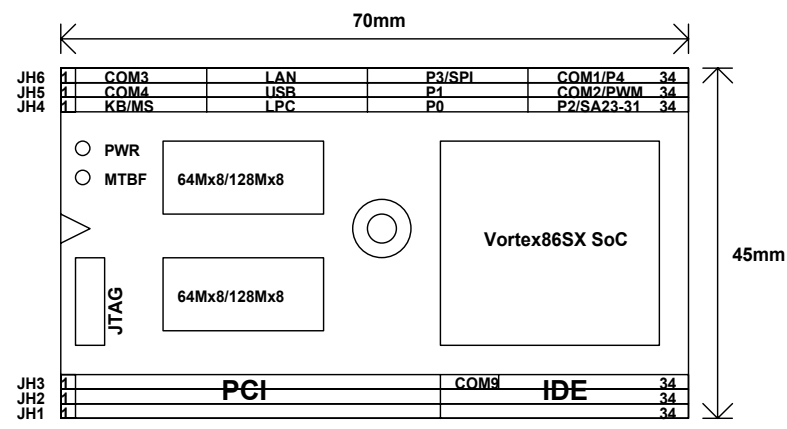

Vortex86SX SoM DIP-204-PCI

DMP ELECTRONICS INC.		
Title CONNECTOR		
Size	Document Number DM90A	Rev 1.2
Date:	Monday, February 25, 2008	Sheet 8 of 8