

HARDWARE STRAP

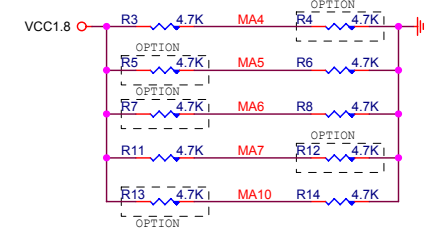

MA5,6,7: CPU CLOCK Select
 MA4,10: DRAM CLOCK Select

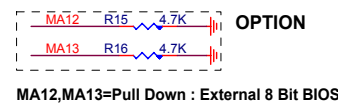

MA12,MA13=Pull Down : External 8 Bit BIOS

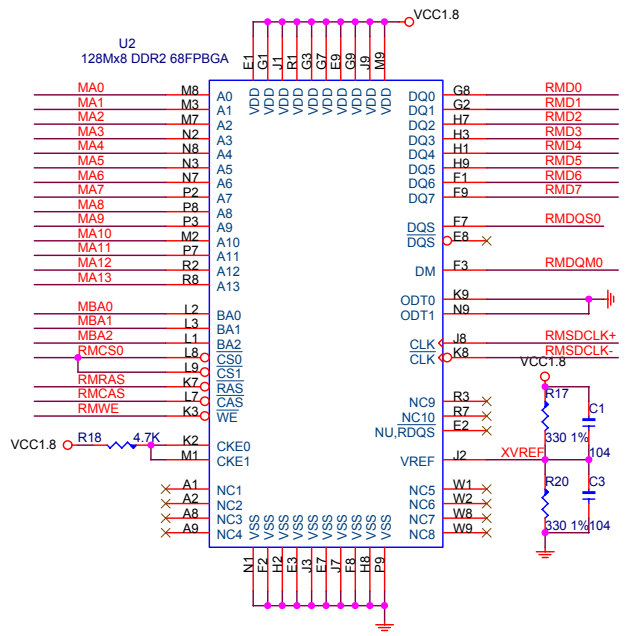

DDR-II SDRAM
 64Mx8x2 =128MB
 128Mx8x2 =256MB

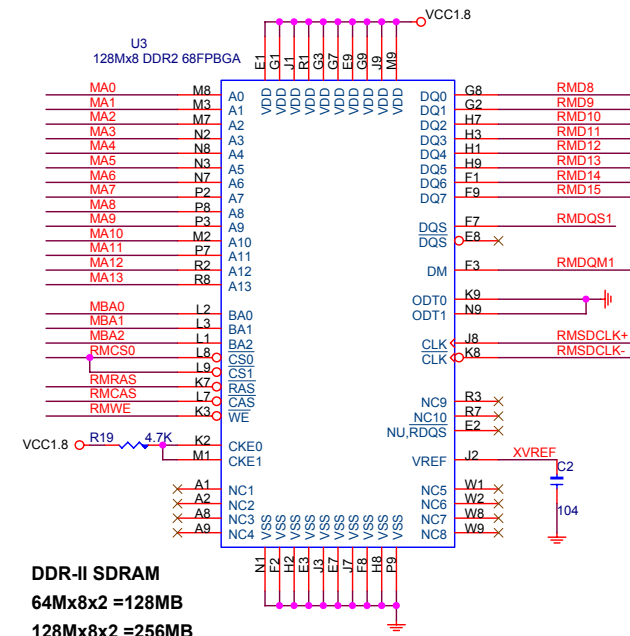

PCB NO. DM89A
 Vortex86SX SOC DIP-204 ISA Module
 VER :1.2

DMP ELECTRONICS INC.		
Title Vortex86SX DDR-II Memory		
Size	Document Number DM89A	Rev 1.2
Date:	Monday, February 25, 2008	Sheet 1 of 8

ISA BUS

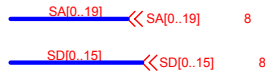

Vortex86SX-NOSKT U1B

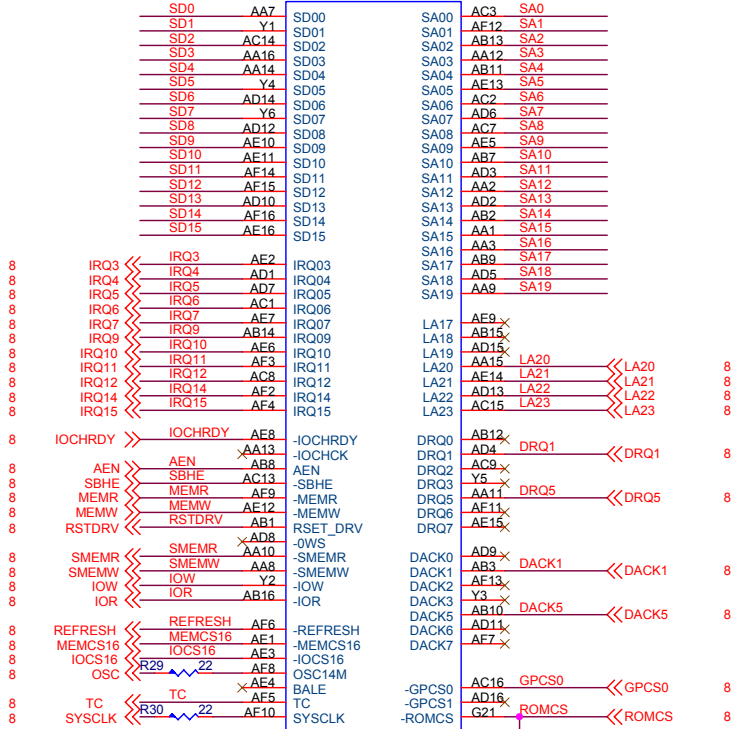

OPTION PULL UP

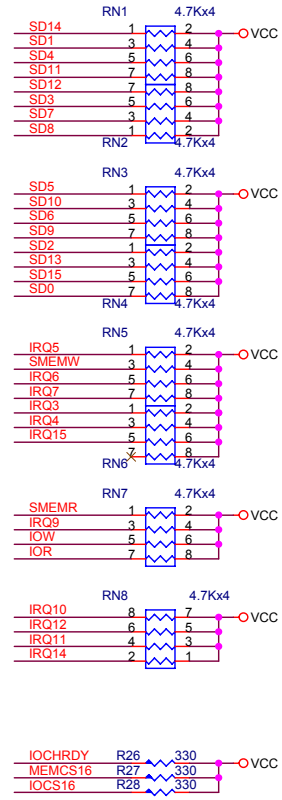

PCI BUS

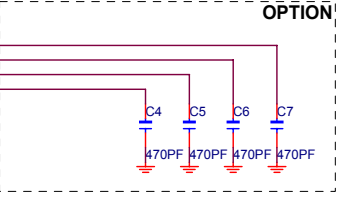
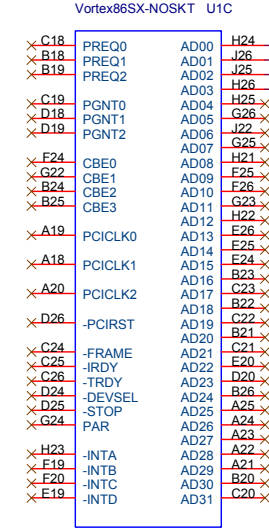

DMP ELECTRONICS INC.

Title		
Vortex86SX PCI/ISA BUS		
Size	Document Number	Rev
	DM89A	1.2
Date:	Monday, February 25, 2008	Sheet 3 of 8

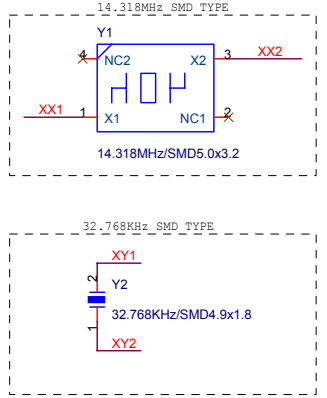
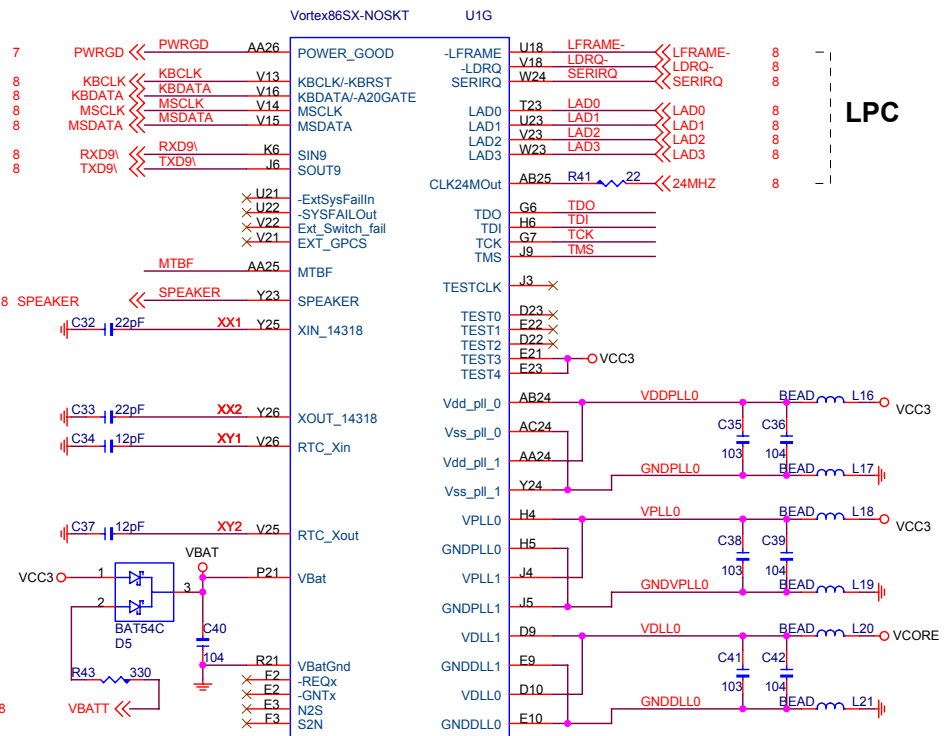

JTAG

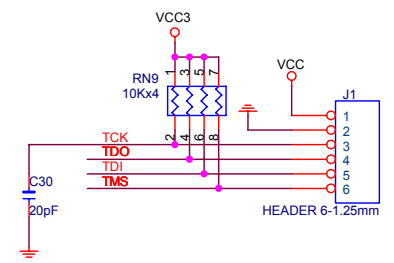

RESET

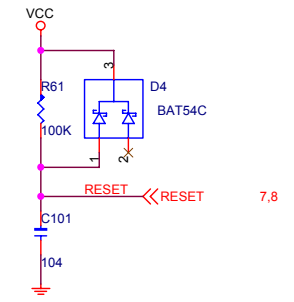

KBD/MOUSE

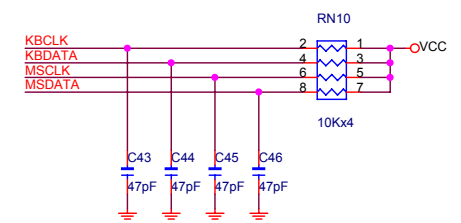

POWER LED



MTBF LED

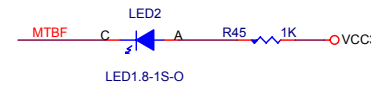

DMP ELECTRONICS INC.		
Title Vortex86SXKBD/MS/LPC/JTAG		
Size	Document Number DM89A	Rev 1.2
Date:	Monday, February 25, 2008	Sheet 5 of 8

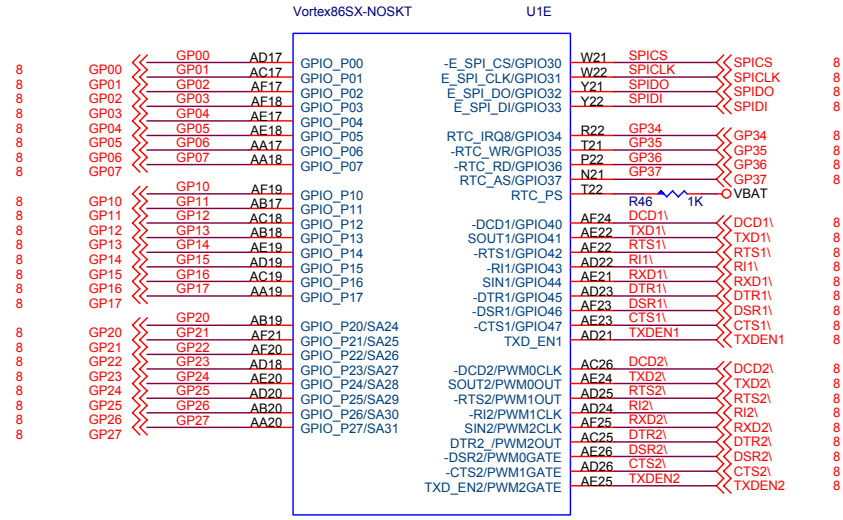

External SPI FLASH 2MB

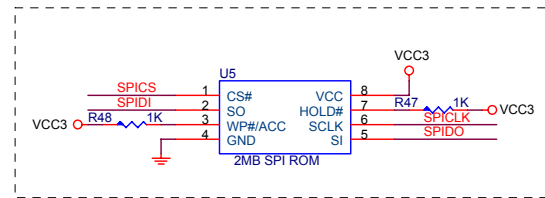

DMP ELECTRONICS INC.



Title		
Vortex86SX GPIO/COM/PWM		
Size	Document Number	Rev
	DM89A	1.2
Date:	Monday, February 25, 2008	Sheet 6 of 8

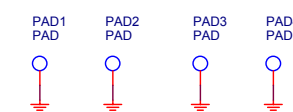
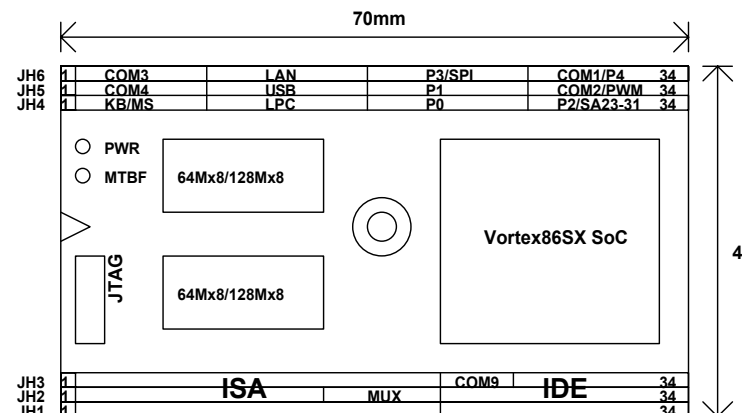
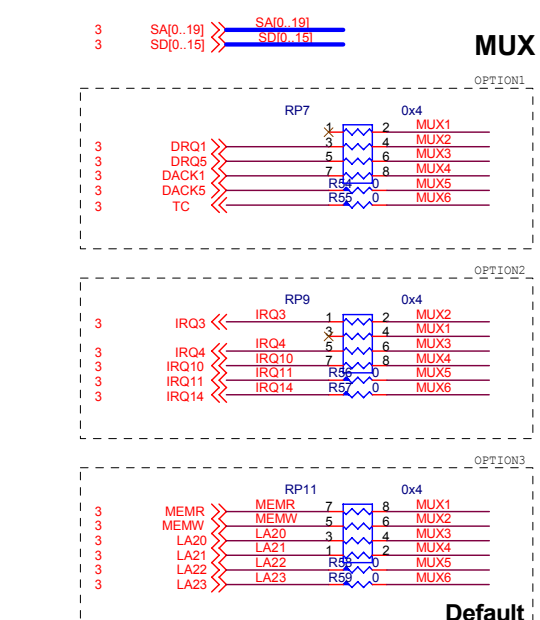
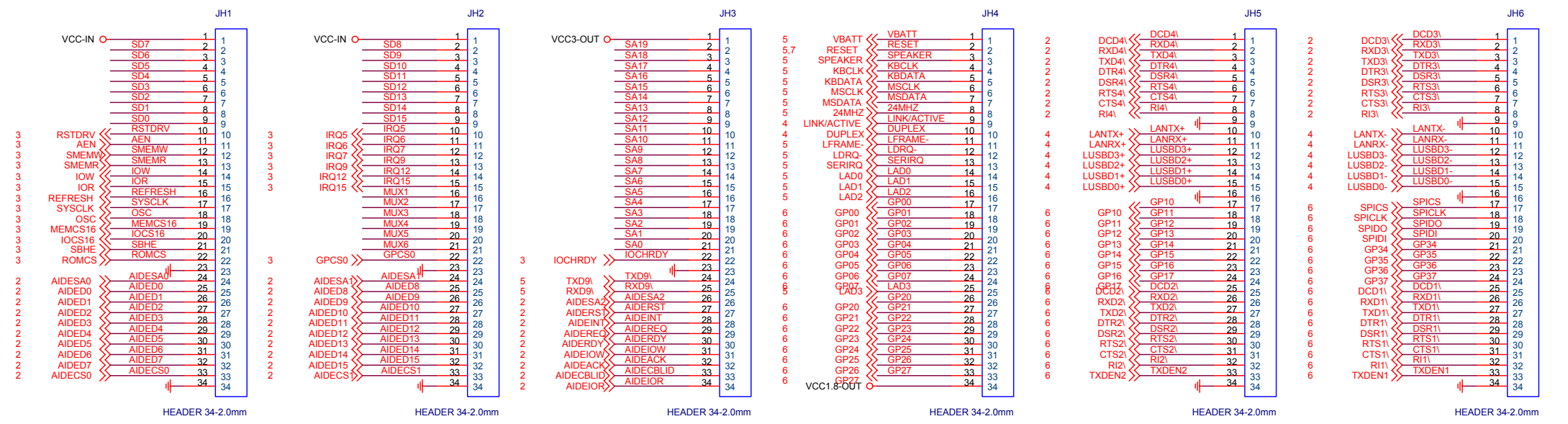

Vortex86SX SoM DIP-204-ISA

DMP ELECTRONICS INC.

Title: CONNECTOR

Size: Document Number DM89A Rev 1.2

Date: Monday, February 25, 2008 Sheet 8 of 8