

### HARDWARE STRAP

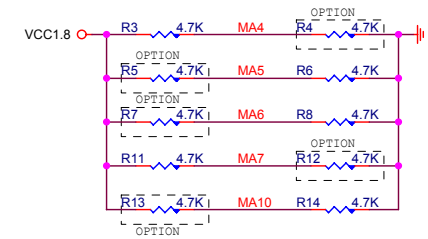

MA5,6,7: CPU CLOCK Select **300MHz**

MA4,10: DRAM CLOCK Select **133MHz**

DDR-II SDRAM  
 64Mx8x2 =128MB  
 128Mx8x2 =256MB

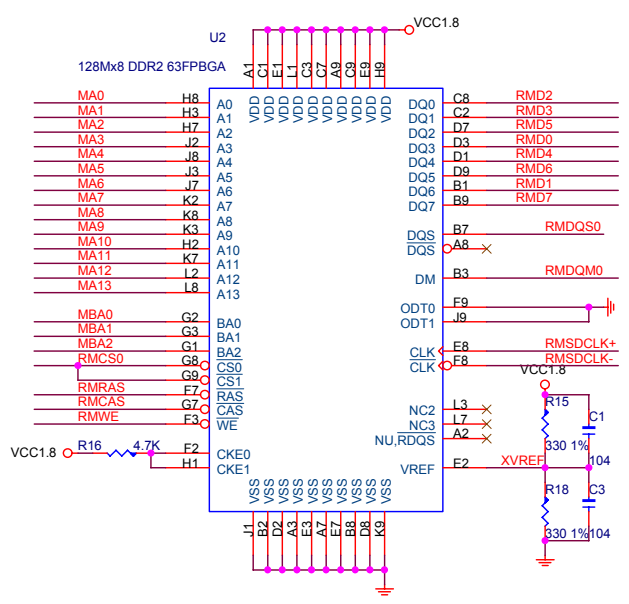

DDR-II SDRAM  
 64Mx8x2 =128MB  
 128Mx8x2 =256MB

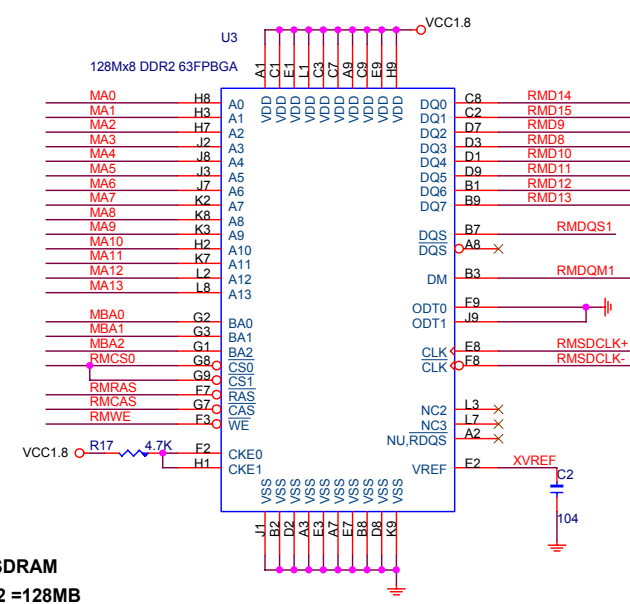

PCB NO. DM93B  
 Vortex86SX Mity-SOC With NANDrive  
 VER :1.2

DMP ELECTRONICS INC.		
Title Vortex86SX DDR-II Memory		
Size	Document Number DM93B	Rev 1.2
Date	Friday, April 18, 2008	Sheet 1 of 8

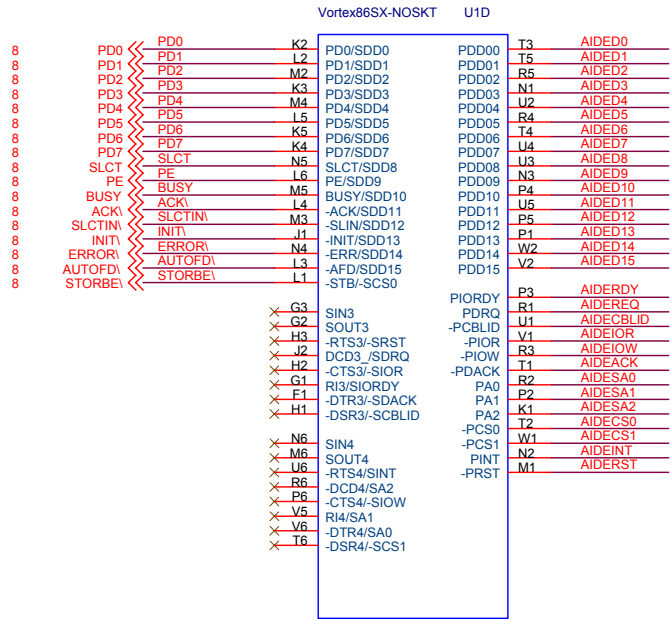

IDE

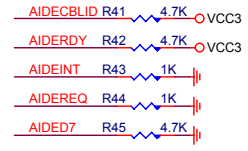

U9 SST NANDrive (91ball TFBGA 12x18)

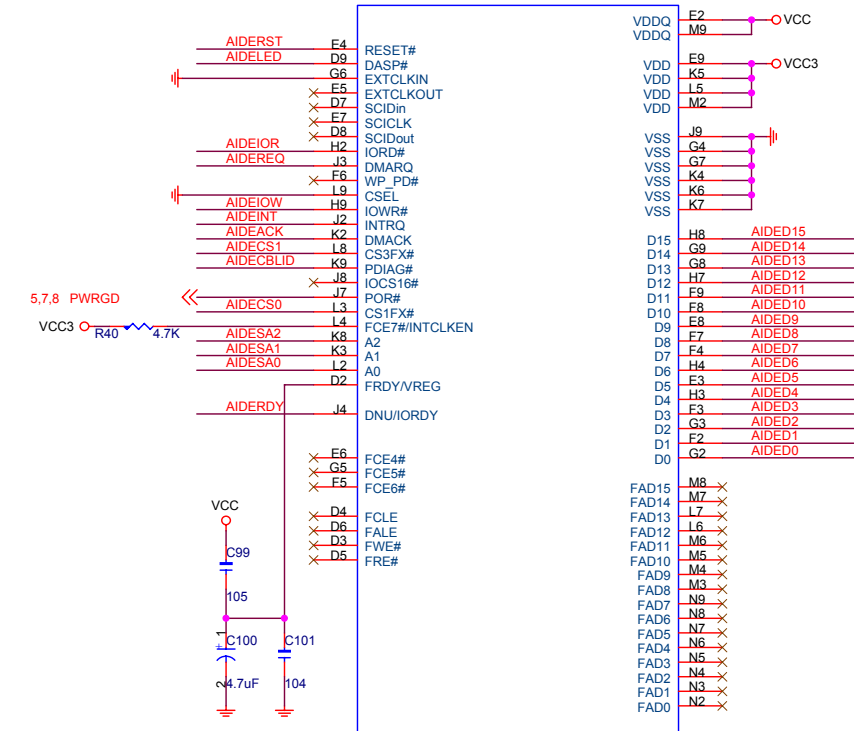

**NANDrive SST85LD0128-120-C 128MB**  
**128MB/256MB/512MB**

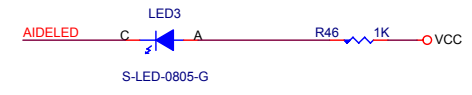

**DMP ELECTRONICS INC.**

Title: Vortex86SX IDE

Size: Document Number DM93B Rev: 1.2

Date: Friday, April 18, 2008 Sheet 2 of 8

# ISA BUS

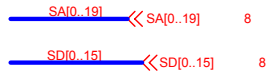

Vortex86SX-NOSKT U1B

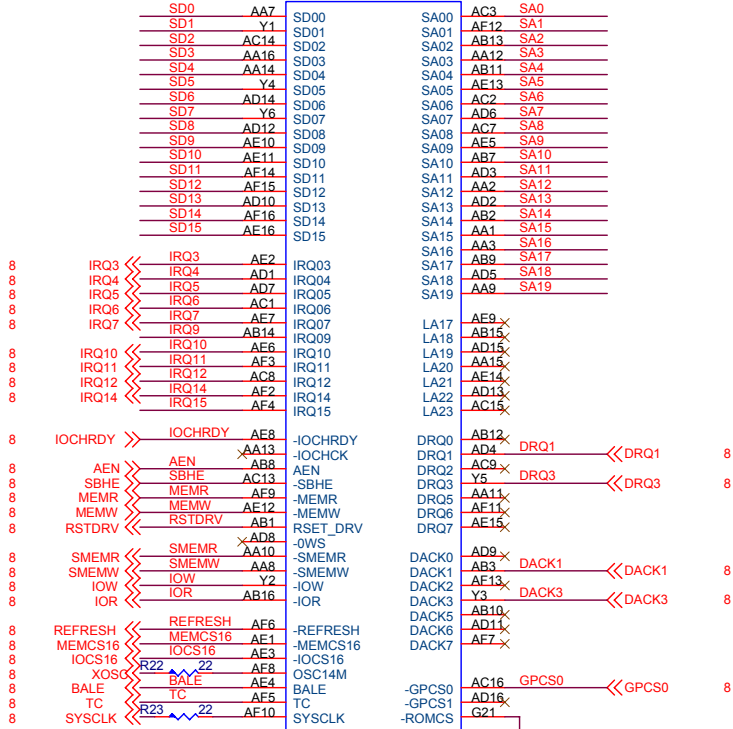

# OPTION PULL UP

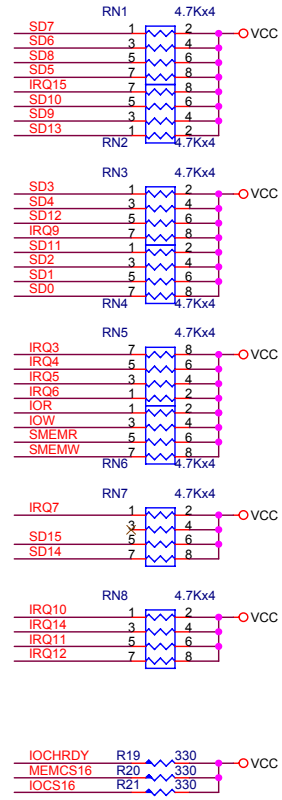

# PCI BUS

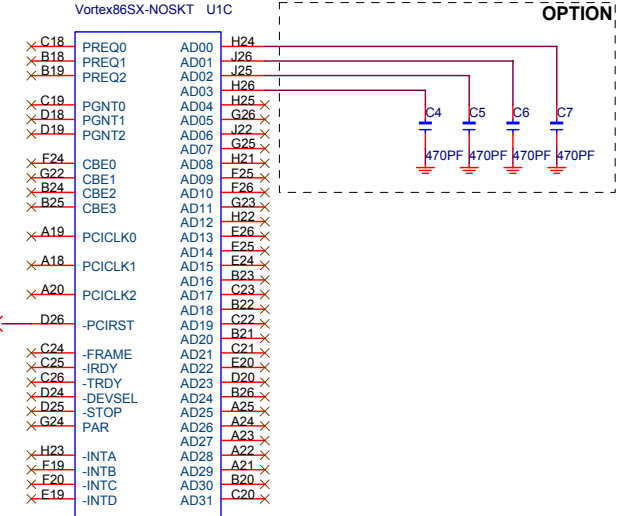

**DMP ELECTRONICS INC.**

Title: Vortex86SX PCI/ISA BUS

Size: Document Number DM93B Rev 1.2

Date: Friday, April 18, 2008 Sheet 3 of 8

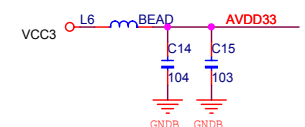
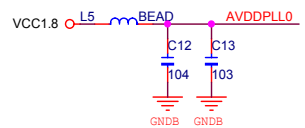
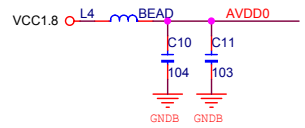
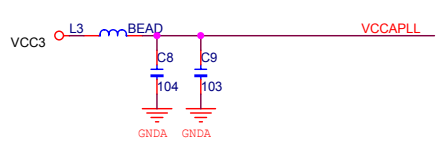
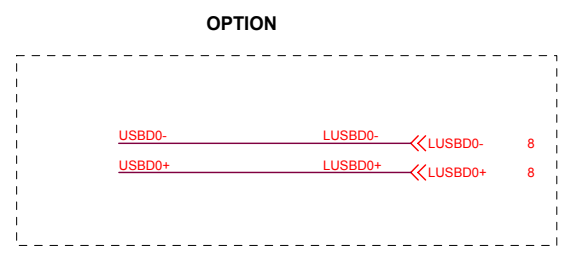
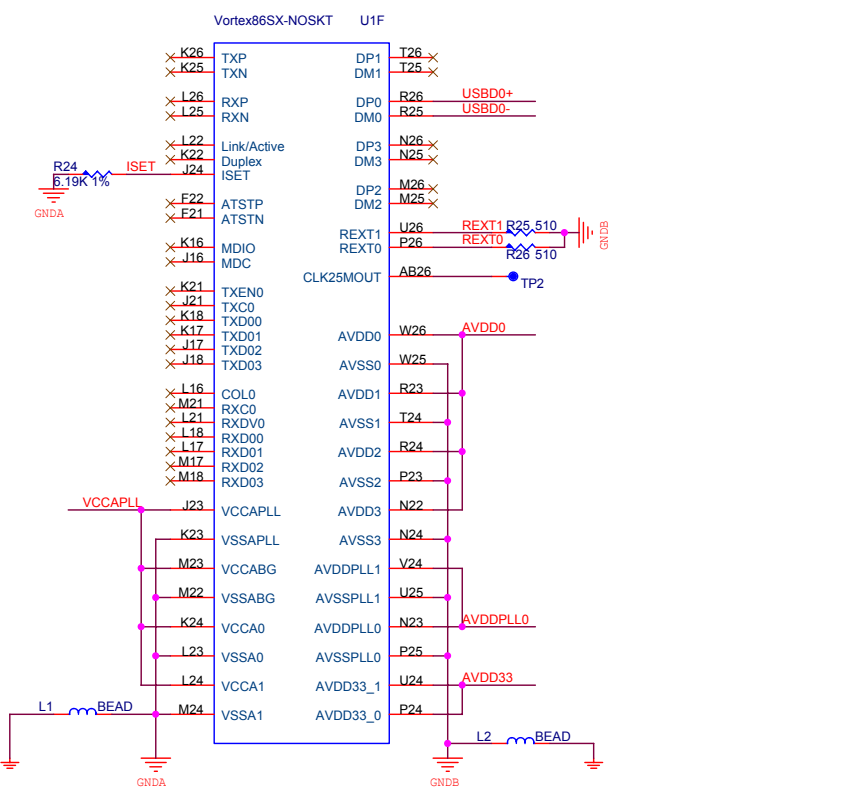

PHY ANALOG GND

USB ANALOG GND

DMP ELECTRONICS INC.



Title		
Vortex86SX LAN/USB		
Size	Document Number	Rev
	DM93B	1.2
Date:	Friday, April 18, 2008	Sheet 4 of 8

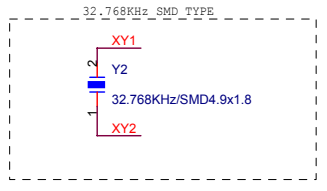
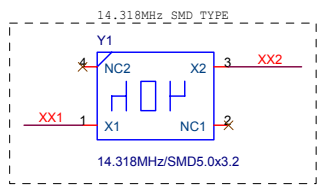
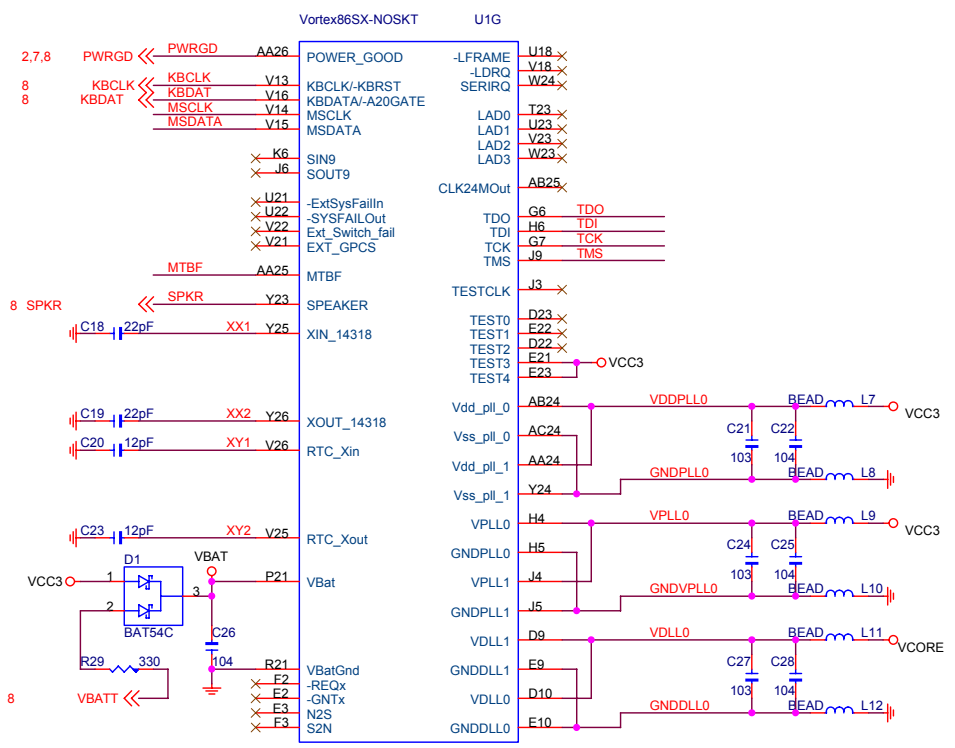

### JTAG

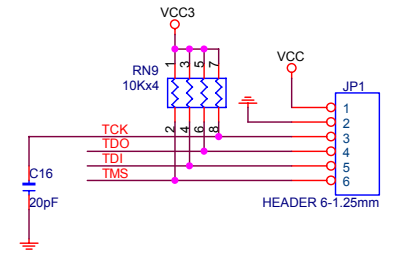

### KBD/MOUSE

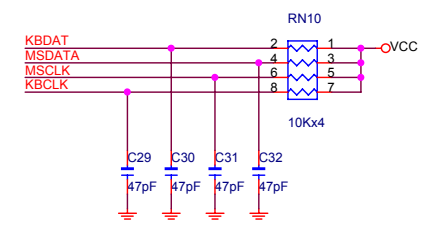

### POWER LED

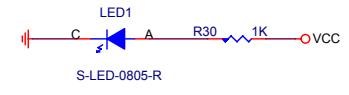

### MTBF LED

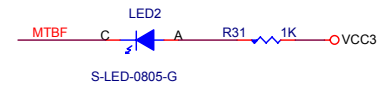

### DMP ELECTRONICS INC.

Title		
Vortex86SXKBD/MS/LPC/JTAG		
Size	Document Number	Rev
	DM93B	1.2
Date:	Friday, April 18, 2008	Sheet 5 of 8

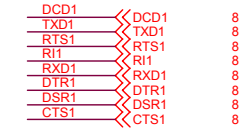
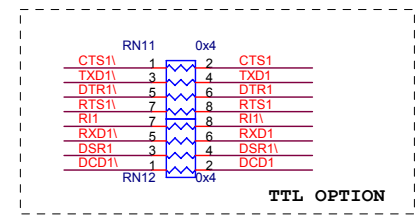
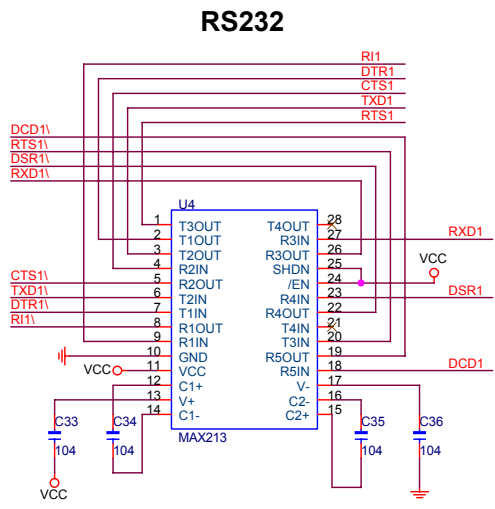
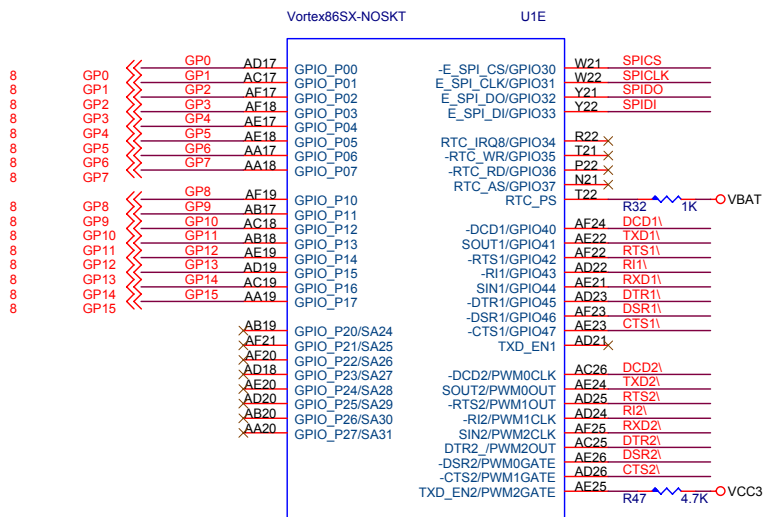

**External SPI FLASH 2MB**

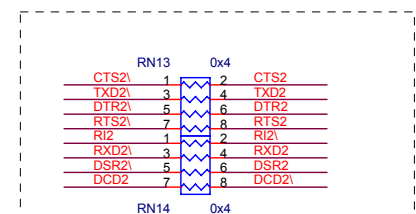
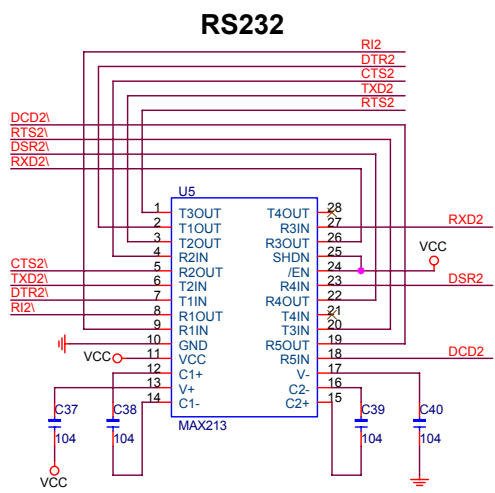
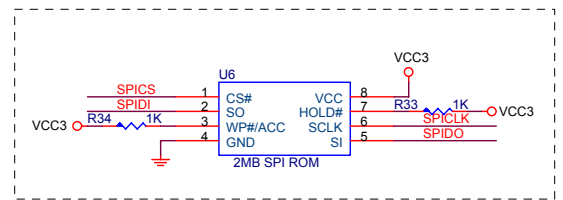

**DMP ELECTRONICS INC.**



Title		
Vortex86SX GPIO/COM/PWM		
Size	Document Number	Rev
	DM93B	1.2
Date:	Friday, April 18, 2008	Sheet 6 of 8



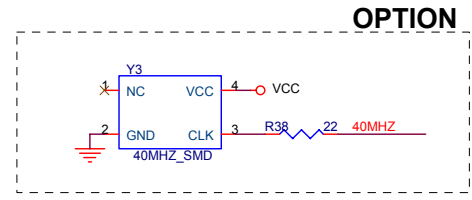
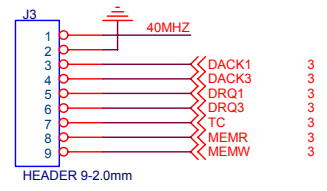
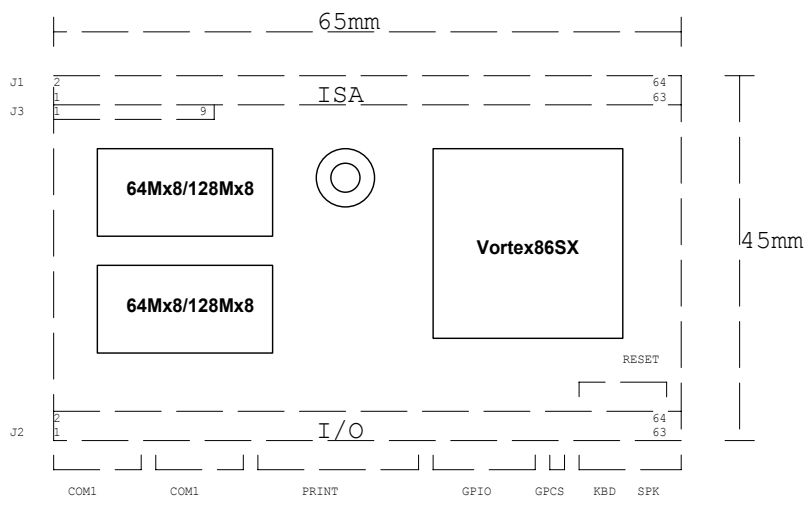
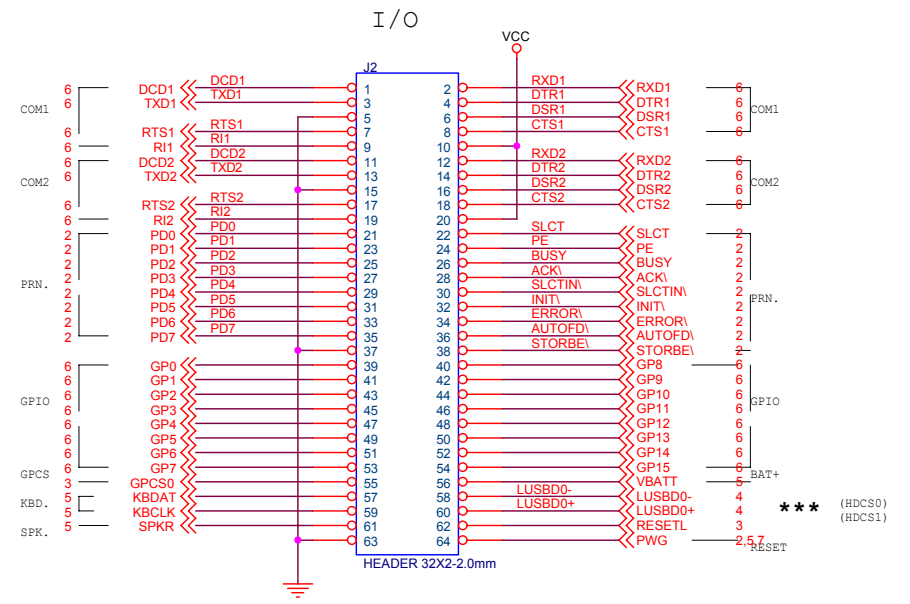
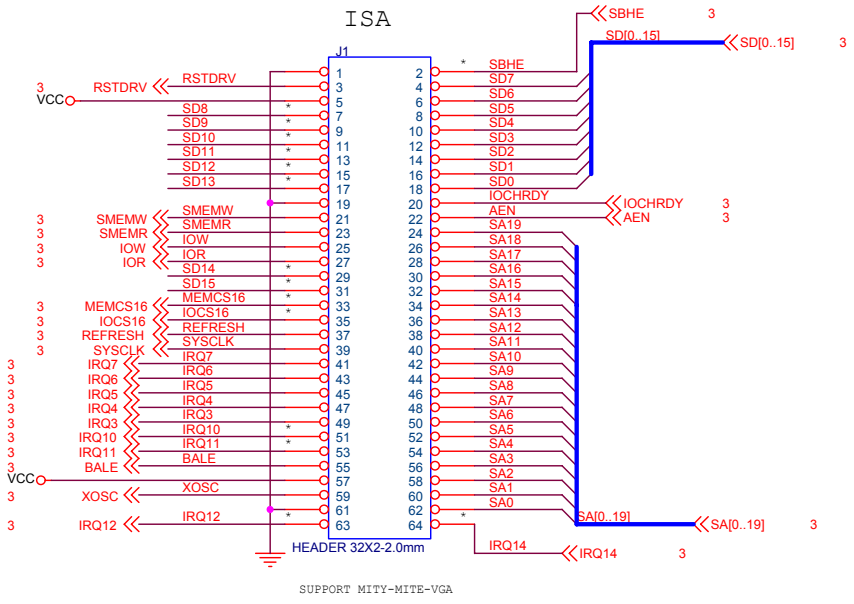

**DMP ELECTRONICS INC.**

Title: CONNECTOR

Size: Document Number: Rev: 1.2

Date: Friday, April 18, 2008 Sheet: 8 of 8