

## Vortex86SX SOC DIP-68 Module

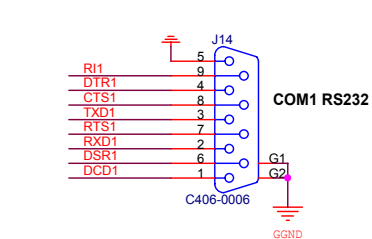

## Vortex86SX DIP-68/DIP-48 EVB

Rev B PCB NO. DM79A

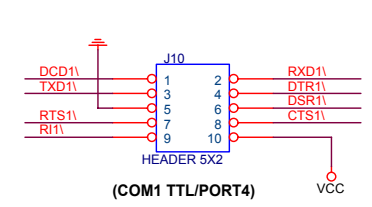
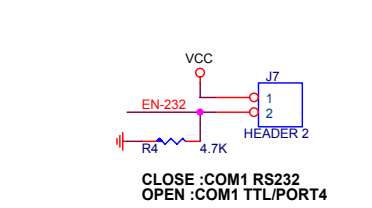
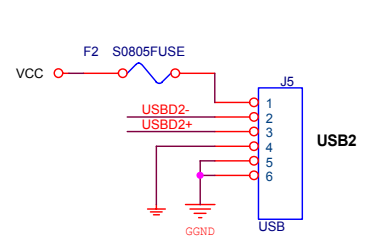
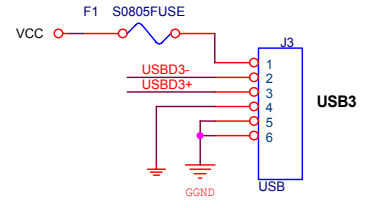
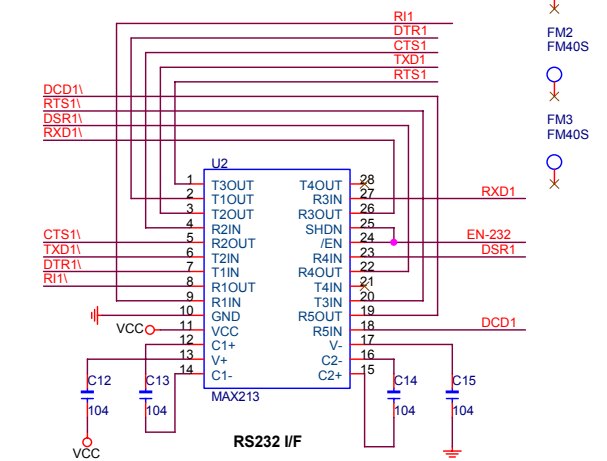
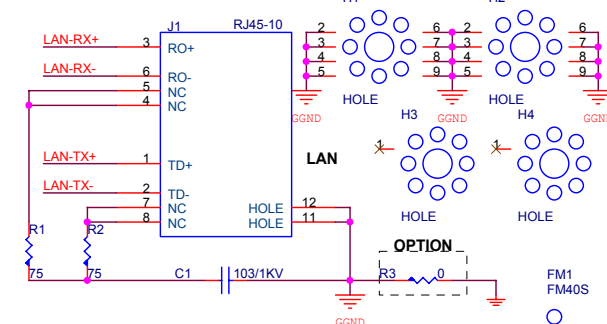
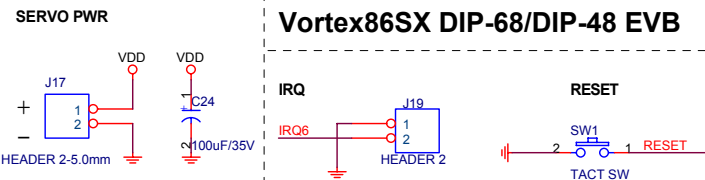
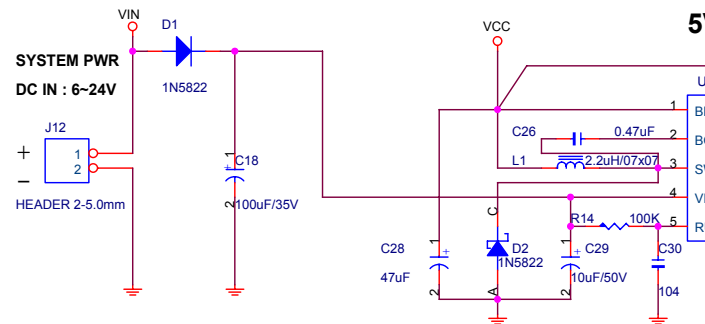
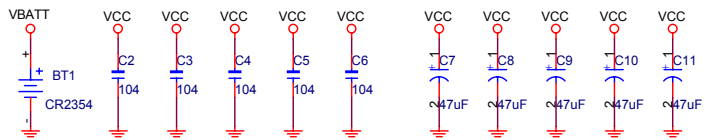
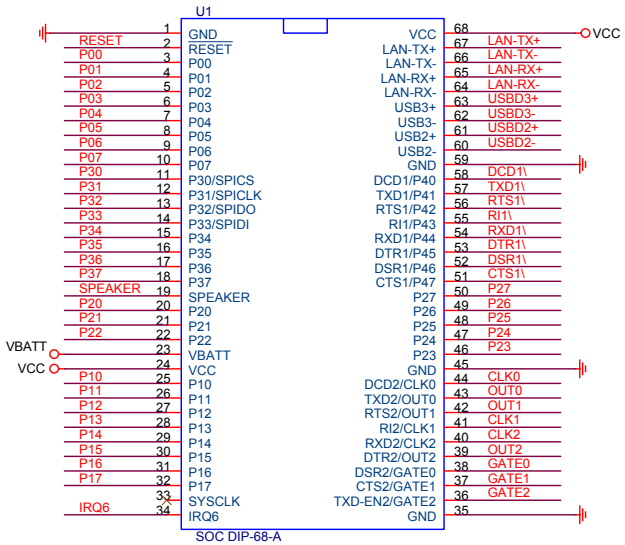
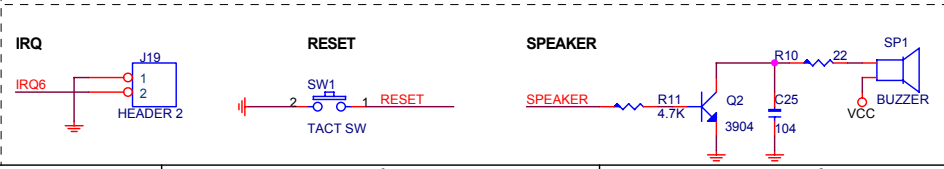

DMP ELECTRONICS INC.		
Title: DIP-68/DIP-48 EVB		
Size: Document Number	DM79A	Rev: B
Date: Friday, January 18, 2008	Sheet: 1	of: 1